



ZANOTTI Spa
Via M.L. King, 30
46020 - Pegognaga (MN) - ITALY
Tel. +39 0376 5551
Fax +39 0376 536554
info@zanotti.com

Tarjeta técnica máquina

Versión 1.35

Modelo:

MRS225N01F

Categoría:

Uniblock RS

Datos técnicos

Características	U.M.	Valor
Temperatura trabajo	°C	+10 ÷ -5
Arranque		Directo
Voltaje	Volt-Ph-Hz	230/1~/50
Absorción nominal	kW*	1,10
Absorción nominal	Amp*	7,00
Corriente de arranque	Amp	36,0
Corriente máxima	Amp	12,7
Refrigerante		R404A
Desescarche		Eléctrico
Calentadores para descongelar	watt	2050
Masa	Kg	121

Compresor

Tipo		Hermético
Potencia nominal	kW	0,7

Condensador

Volumen de aire	m³/h	1850
-----------------	------	------

Evaporador

Volumen de aire	m³/h	1800
Proyección aire	m**	6

Categoría PED		1
---------------	--	---



Datos de la energía

Tc °C	Ta °C	P watt	P Kcal/h	V100 m³	V80 m³	V60 m³
	20	3070	2640	42	38	35
	25	2876	2473	38	35	32
10	30	2690	2313	35	32	29
	35	2511	2159	32	29	27
	40	2339	2012	28	25	23
	45	2171	1867	25	23	21
	20	2696	2319	35	32	29
	25	2522	2169	32	29	27
5	30	2356	2026	29	26	24
	35	2198	1890	26	24	22
	40	2044	1758	23	21	19
	45	1895	1630	20	18	17
	20	2351	2022	29	26	24
	25	2199	1891	26	24	22
0	30	2053	1766	23	21	19
	35	1914	1646	21	19	17
	40	1780	1531	18	16	15
	45	1649	1418	17	15	14
	20	2009	1728	23	21	19
	25	1874	1612	20	18	17
-5	30	1747	1502	18	16	15
	35	1626	1398	17	15	14
	40	1509	1298	15	14	12
	45	1393	1198	14	13	12

* En funcionamiento: 0 ÷ +30°C

** Utilizar como mera indicación. La proyección del aire depende de numerosos factores: altura de la cámara, almacenamiento del producto, posición del evap.etc.

Tc: Temperatura cámara fría - TA:Temperatura externa.

P: Capacidad refrigerante - V: Volumen del cámara de Reccomanded

Dimensioni - Dimensions - Dimensions
Abmessungen - Dimensiones

RS225

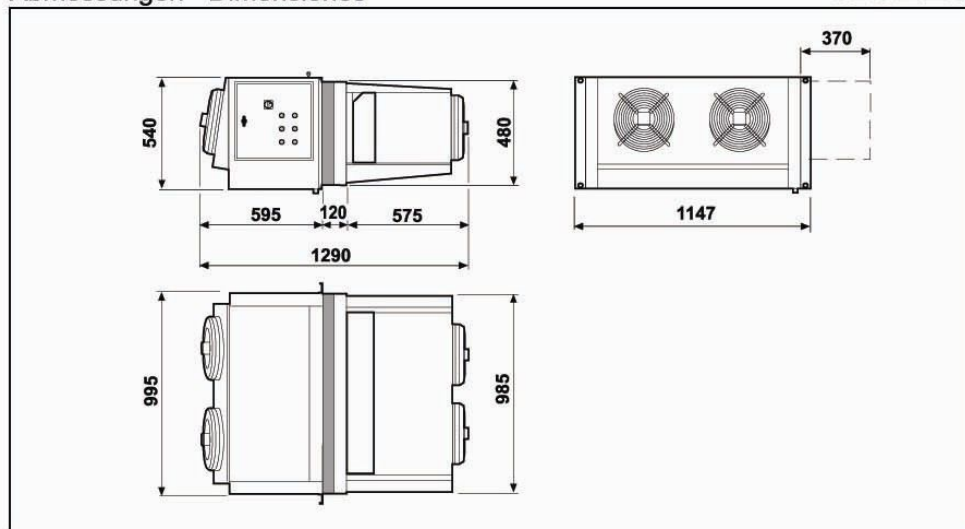

Schema di montaggio - Mounting scheme - Schema de montage
Montageschema - Esquema de montaje

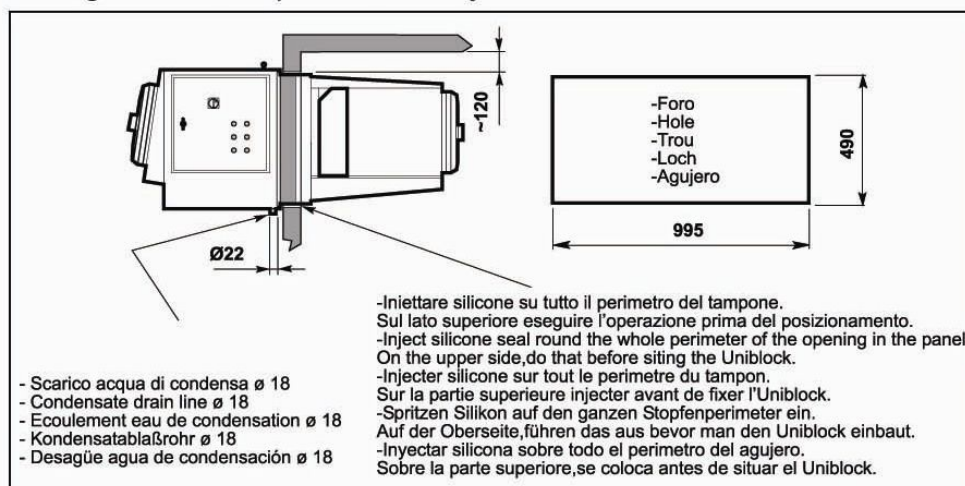

- * Raccomandazioni in sede di installazione e per il controllo fornite sul manuale di installazione
- * To be advised at time of order for factory installation and operating instructions
- * Recommendations au moments d'installations et pour le contrôle fournis sur le manuel d'installation
- * Empfehlungen für die Installationsphase und zur Kontrolle, die im Handbuch zur Installation enthalten sind
- * Por cuanto respecta a recomendaciones de instalación y control ver manual de instalación

Massa e misure imballi - Packing mass and dimensions - Masse et dimensions emballages
Verpackungsmasse und-abmessungen - Masa y medidas del embalaje

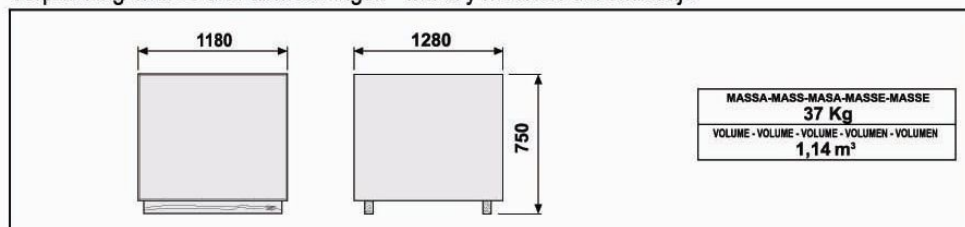

ZANOTTI S.p.A.